

PRODUCT DATA

SERIAL#	LB/FT	SERIAL #	LB/FT
W2-NH	5.8	W3-1H	17.9
W3-NH	7.9	W3-2H	27
W4-NH	10.6	W4-1H	21
W2-1H	16.3	W4-2H	42
W2-2H	26.8		

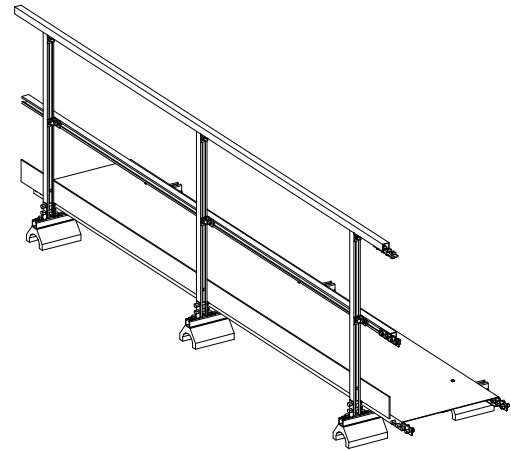

3D view

PRODUCT GENERAL NOTES:

- STEEL FINISH IS GALVANIZED.
- CUSTOM SIZES ARE AVAILABLE UPON REQUEST.
- WEIGHT ARE APPROXIMATED.
- SHIPPING MAYBE IN STANDARD PALLET SIZE OR IN 12 FT SECTIONS.

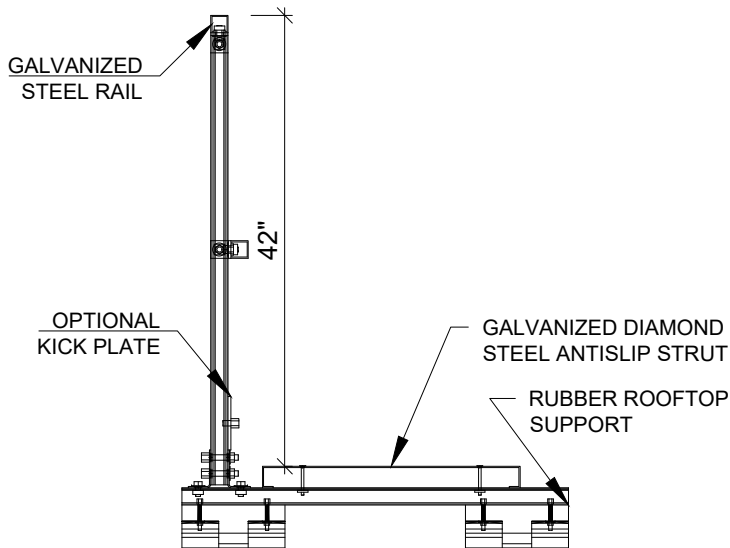
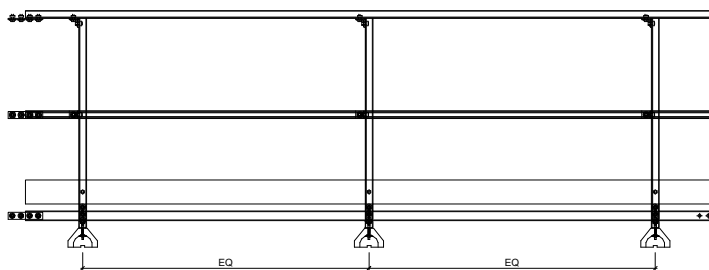
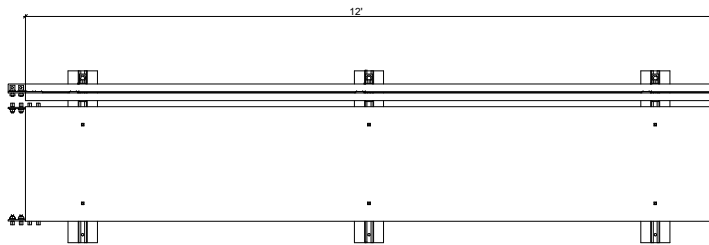

- W2-1H (2 FT WIDE X ONE SIDE RAIL)
- W2-2H (2 FT WIDE X TWO SIDE RAIL)
- W3-1H (3 FT WIDE X ONE SIDE RAIL)
- W3-2H (3 FT WIDE X TWO SIDE RAIL)
- W4-1H (4 FT WIDE X ONE SIDE RAIL)
- W4-2H (4 FT WIDE X TWO SIDE RAIL)

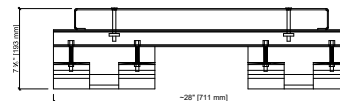

- W2-NH (2 FOOT WIDE)
- W3-NH (3 FOOT WIDE)
- W4-NH (4 FOOT WIDE)



Profound Engineering Inc.
 Suite 3400, 10180 101 Street NW
 Edmonton, AB
 T5J 3S4
 Email: info@profoundeng.com
 Tel: +1 587 743 0842

SCALE:
NTS

DESCRIPTION

STANDARD ANTISLIP ROOF WALKWAYS

No. Project

DRG No.
W-0100

Rev.

